

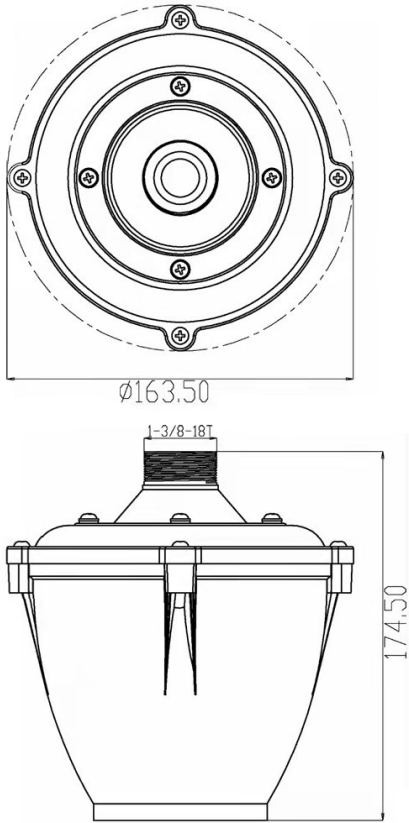

100W PA Speaker Horn Driver with 70V Transformer

D100T



PARAMETERS

Nominal Input	70.7 V
RMS Power Handling	100 watts
Frequency Response	200 – 9,000 Hz
Horn Coupling	1-3/8" – 18
Impedance	No Bypass
SPL (dB)	110 dB @ 1W/1m
Weatherproof	Yes
Diaphragm Material	Phenolic
Voice Coil Material	Kapton / Copper
VC Diameter	2"
Weight	6.3 lbs
Transformer Tabs (W)	12.5, 25, 50, 100

FEATURES

- High power handling
- Durable phenolic diaphragm
- Weather-tight housing
- High output, low distortion
- Integrated 70V transformer with selectable taps
- 1-3/8" -18 TPI threaded horn coupling
- Salt spray tested to ensure durability
- Wiring pigtail included
- Five-year warranty

IMPEDANCE/PHASE

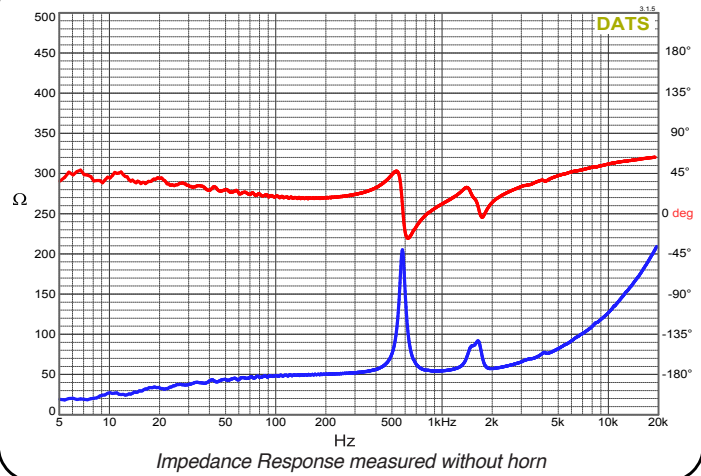

FREQUENCY RESPONSE

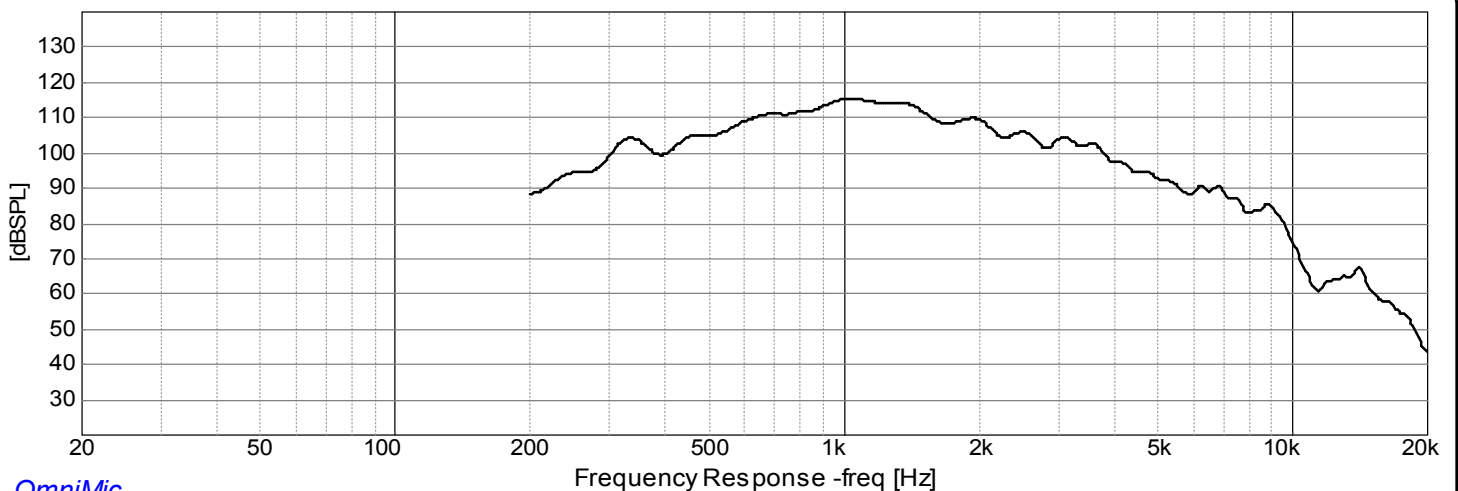

OmniMic

Frequency Response measured on RPH20 Horn @ 1W on 100 watt tap